

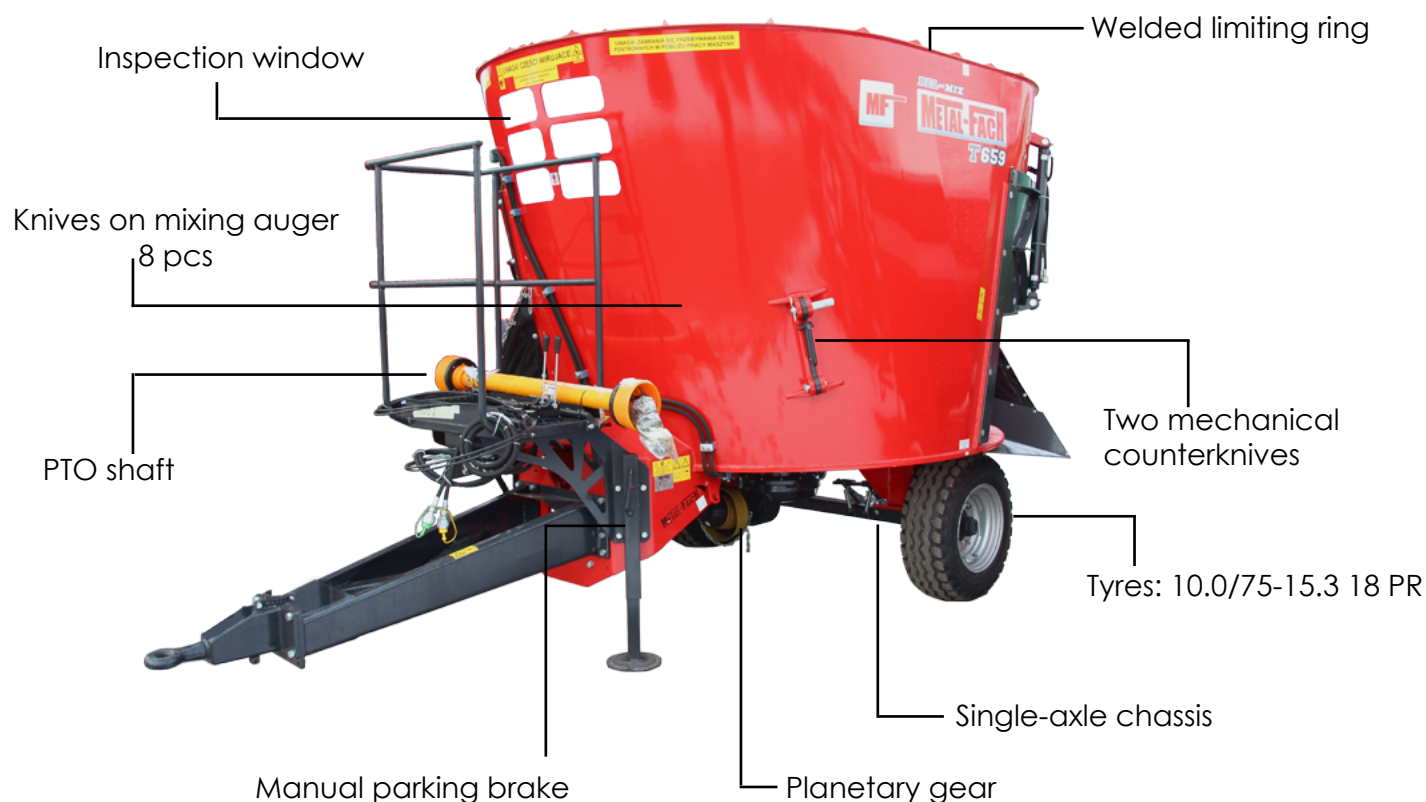

## Feeder wagons



# T659 OPTIMAL single-rotor feeder wagon



Item no.	Type				
1	Capacity [m <sup>3</sup> ]	5	6	7	8
<b>Overall dimensions</b>					
2	Length [mm]	4030	4010	4010	4010
3	Width [mm]	2200	2200	2200	2200
4	Height [mm]	2400	2190	2420	2640
5	Height from the work surface [mm]	1370	1600	1820	1822
<b>Auger characteristics</b>					
6	Width [mm]	2150	2150	2150	2150
7	Height of auger with knife [mm]	1015	1015	1015	1015
<b>Machine characteristics</b>					
8	Floor thickness [mm]	20			
9	Wall thickness [mm]	8			
10	Wagon bottom width [mm]	2200	2200	2200	2200

# T659 BEL-MIX single-rotor feeder wagon

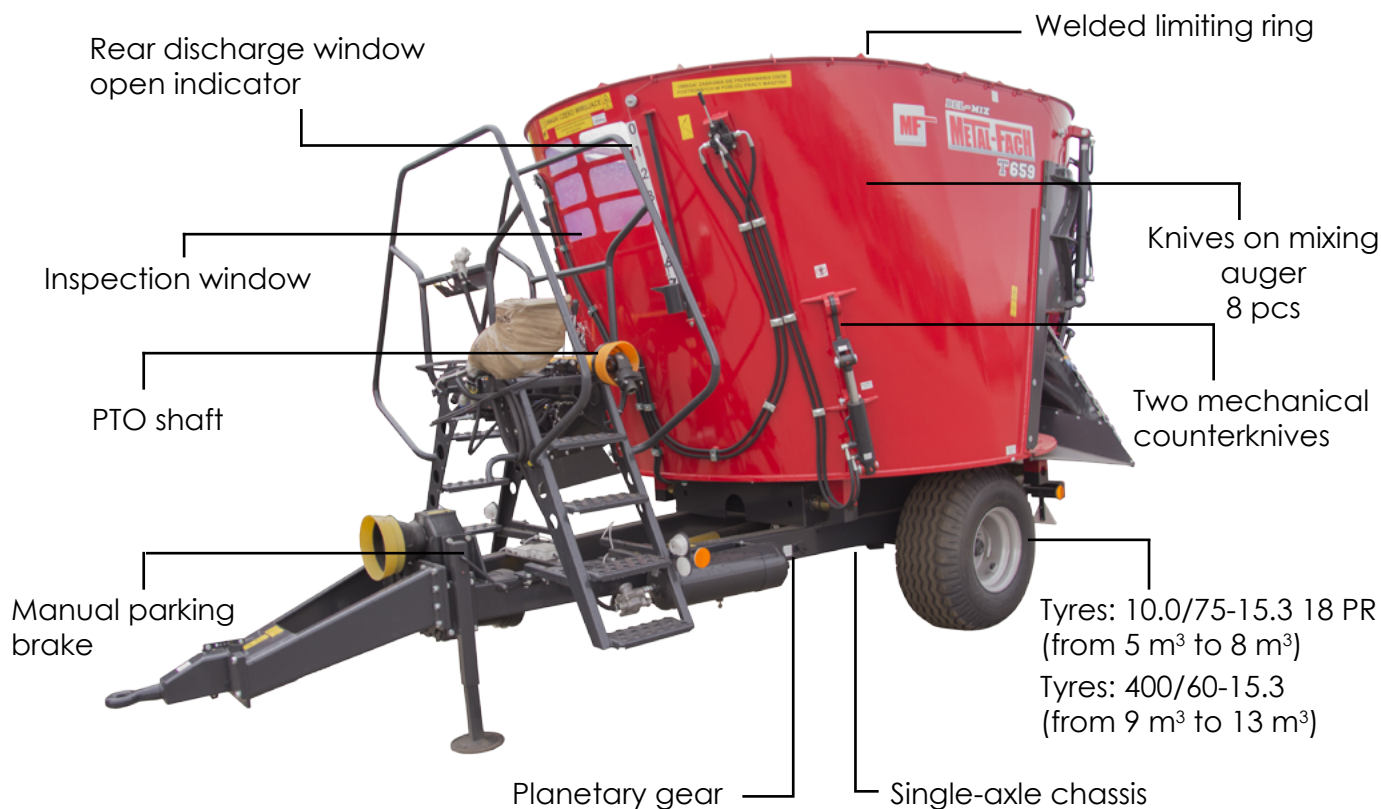

Item no.	Type										
1	Capacity [m <sup>3</sup> ]	5	6	7	8	9	10	11	12	13	
<b>Overall dimensions</b>											
2	Length [mm]	4890	4970	4990	5050	5000	5000	5480	5500	5555	
3	Width [mm]	2200		2520	2400	2500					
4	Height [mm]	2350	2470	2600	2400	2520	2680	2710	2880	3030	
5	Height from the work surface [mm]	1370	1600	1820	1890	1940	2120	1965	2150	2320	
<b>Auger characteristics</b>											
6	Width [mm]	2150		2250	2350	2450					
7	Height of auger with knife [mm]	1015			1300	1305					
<b>Machine characteristics</b>											
8	Floor thickness [mm]	20									
9	Wall thickness [mm]	8									
10	Wagon bottom width [mm]	2200		2300	2400	2500					

# T659 BEL-MIX single-rotor low-floor feeder wagon

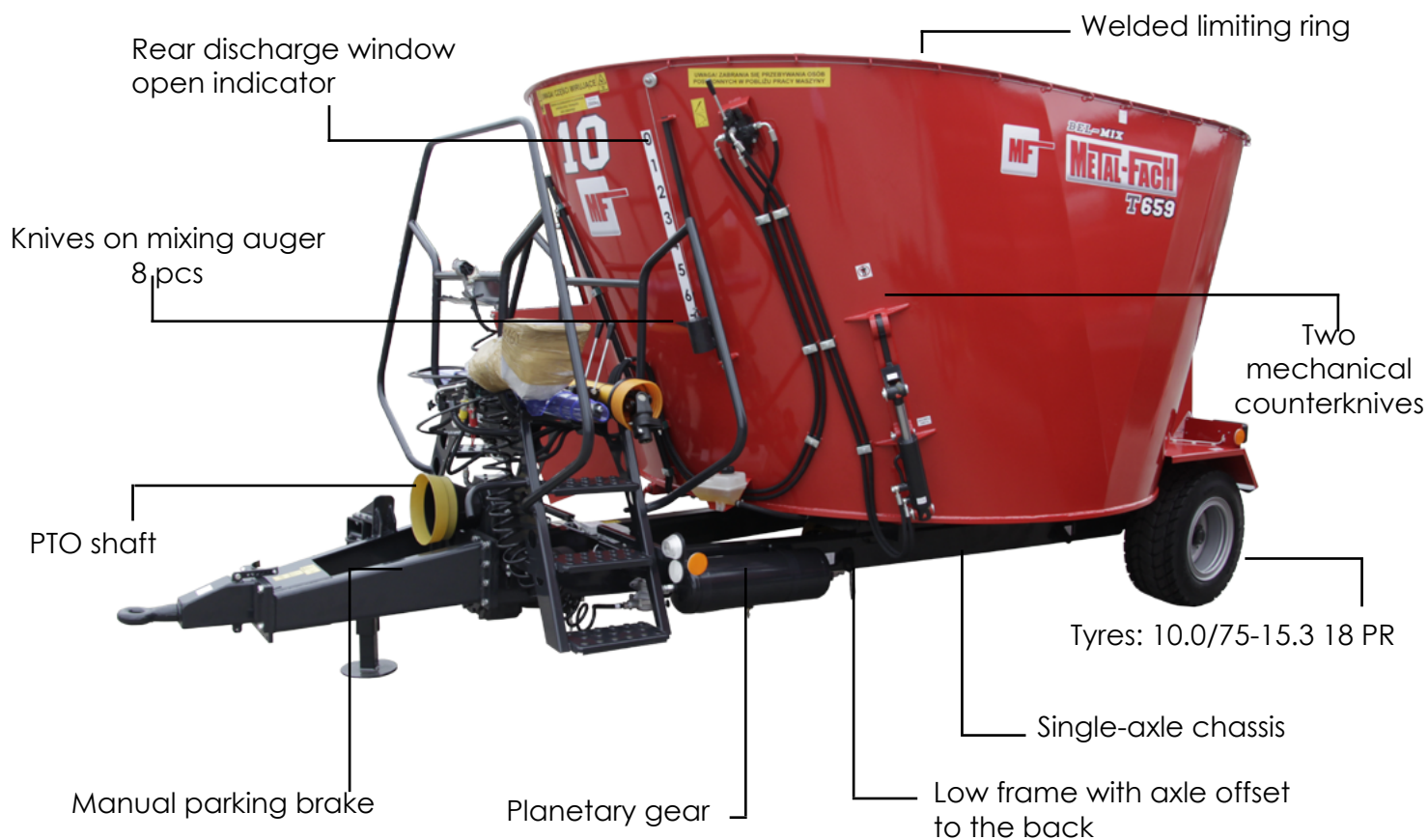

Item no.	Type				
1	Capacity [m <sup>3</sup> ]	6	8	10	12
<b>Overall dimensions</b>					
2	Length [mm]	5000			
3	Width [mm]	2200	2300	2400	2500
4	Height [mm]	2070	2380	2640	2800
5	Height from the work surface [mm]	1370	1680	1940	2150
<b>Auger characteristics</b>					
6	Width [mm]	2150	2250	2350	2450
7	Height of auger with knife [mm]	1015		1300	
<b>Machine characteristics</b>					
8	Floor thickness [mm]	20			
9	Wall thickness [mm]	8			
10	Wagon bottom width [mm]	2200	2300	2400	2500

# T659 BEL-MIX double-rotor single-axle feeder wagon

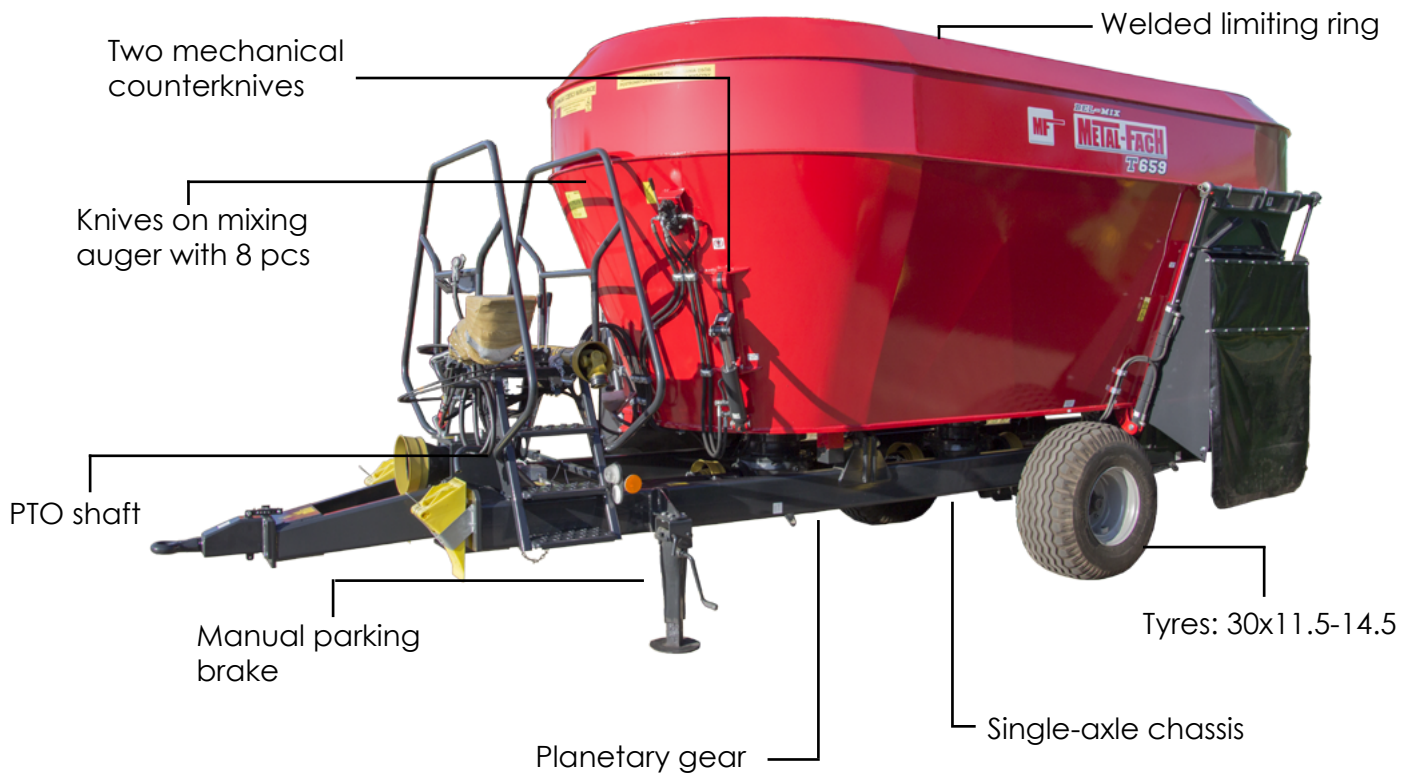

Item no.	Type			
1	Capacity [m <sup>3</sup> ]	10	12	14
<b>Overall dimensions</b>				
2	Length [mm]	5050	5800	6800
3	Width [mm]	2520	2300	2300
4	Height [mm]	2400	2190	2390
5	Height from the work surface [mm]	1300	1300	1500
<b>Auger characteristics</b>				
6	Width [mm]		2250	
7	Height of auger with knife [mm]		1015	
<b>Machine characteristics</b>				
8	Floor thickness [mm]		20	
9	Wall thickness [mm]		8	
10	Wagon bottom width [mm]		2300	

# T659 BEL-MIX double-rotor tandem feeder wagon

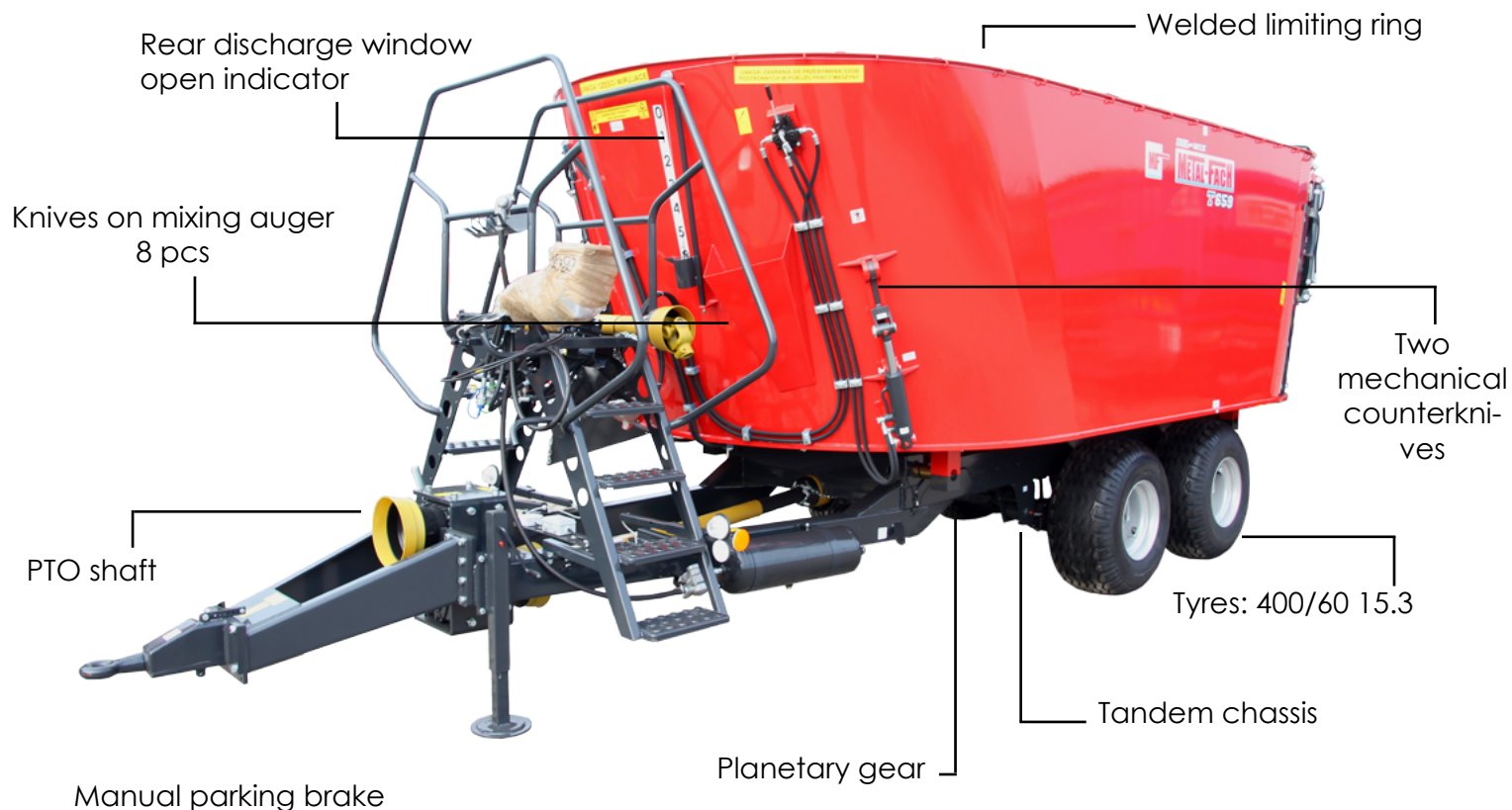

Item no.	Type					
1	Capacity [m <sup>3</sup> ]	14	16	18	20	22
<b>Overall dimensions</b>						
2	Length [mm]	7700				
3	Width [mm]	2300	2400	2500		
4	Height [mm]	2440	2500	2550	2700	2850
5	Height from the work surface [mm]	1500	1560	1750	1930	
<b>Auger characteristics</b>						
6	Width [mm]	2250	2350	2450	2550	
7	Height of auger with knife [mm]	1015	1300			
<b>Machine characteristics</b>						
8	Floor thickness [mm]				20	
9	Wall thickness [mm]				8	
10	Wagon bottom width [mm]	2300	2400	2500		

# T659 BEL-MIX three-rotor tandem feeder wagon

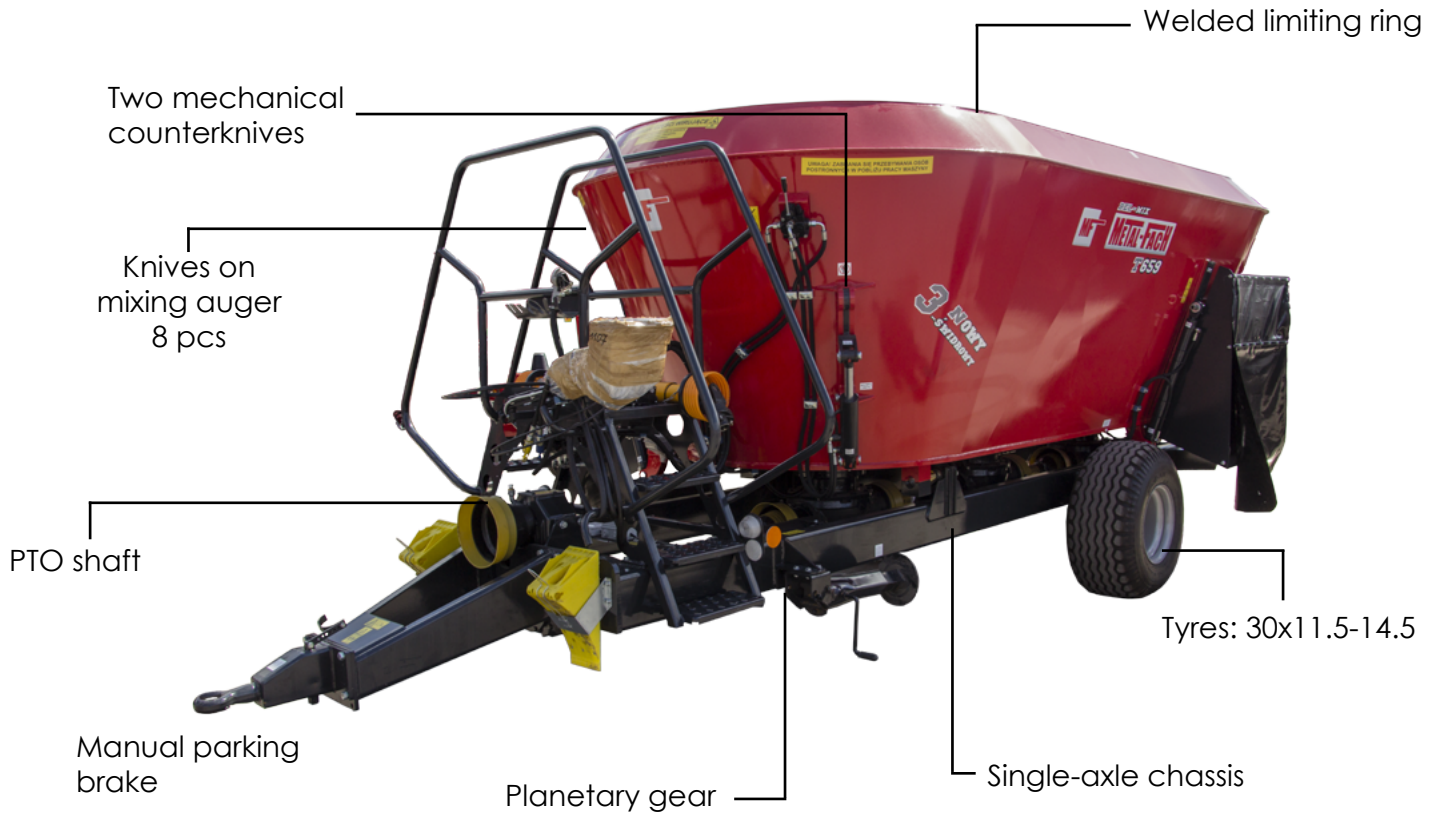

Item no.	Type			
1	Capacity [m <sup>3</sup> ]	24	26	28
<b>Overall dimensions</b>				
2	Length [mm]	9500		
3	Width [mm]	2300	2400	
4	Height [mm]	2700	2680	2750
5	Height from the work surface [mm]	1690	1680	1800
<b>Auger characteristics</b>				
6	Width [mm]	2550		
7	Height of auger with knife [mm]	1300		
<b>Machine characteristics</b>				
8	Floor thickness [mm]	20		
9	Wall thickness [mm]	8		
10	Wagon bottom width [mm]	2250		

# Standard / optional accessories



Inspection window

Standard accessories



Rear discharge window open indicator

Standard accessories



Ø50 mm ring hitch



Ø40 mm automatic ring hitch

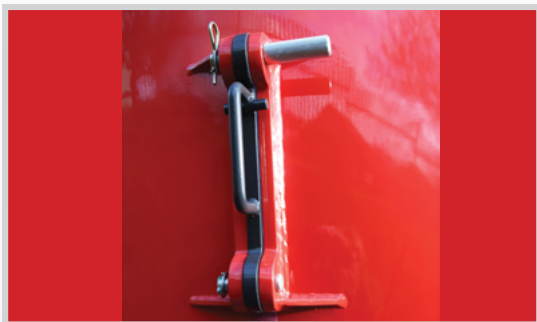

Two mechanical counterknives



Hydraulic counterknives



PTO shaft



Wide-angle drive shaft



# Standard / optional accessories

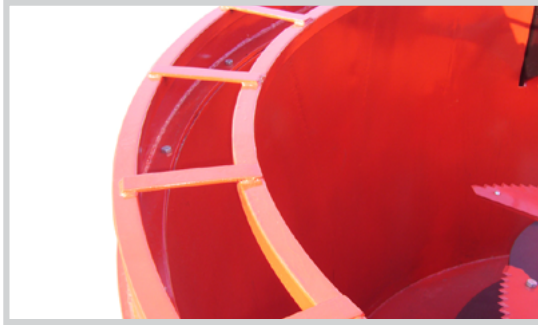

Welded limiting ring



Bolted limiting ring

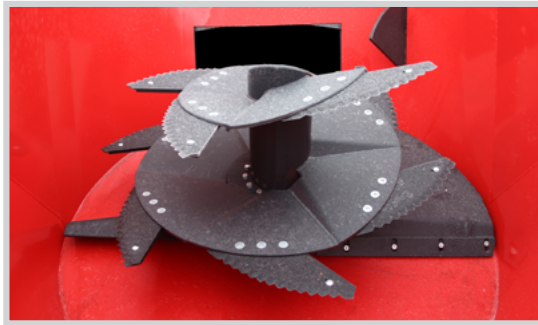

Knives on mixing auger 8 pcs

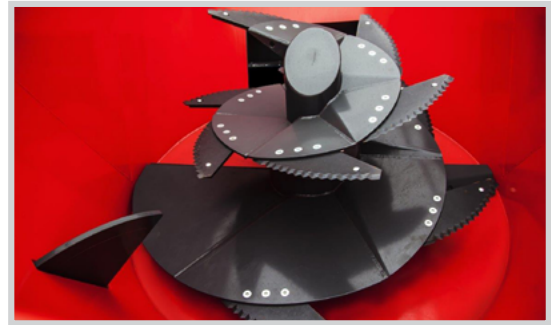

The auger can be fitted with 2 or 3 extra knives



Planetary gear

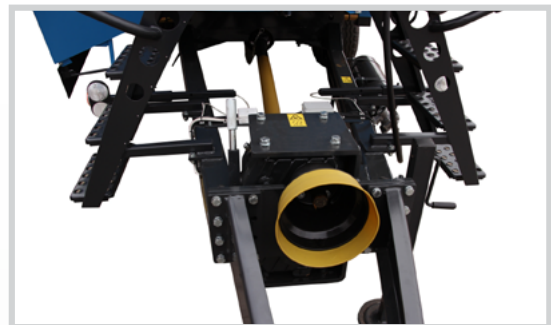

Two-gear transmission

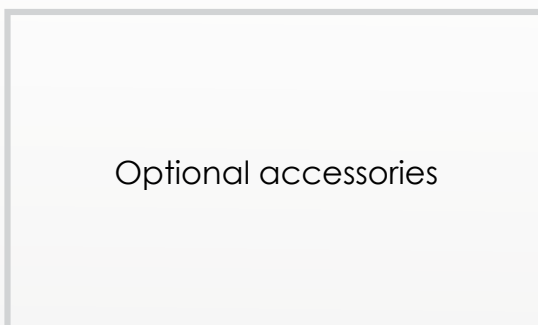

Optional accessories



Top section, increases the wagon capacity to 40 cm

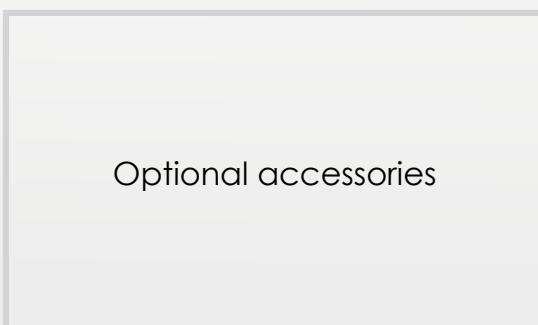

Optional accessories



Electronic weighing system

# Standard / optional accessories



Manual parking brake



Pneumatic brake system

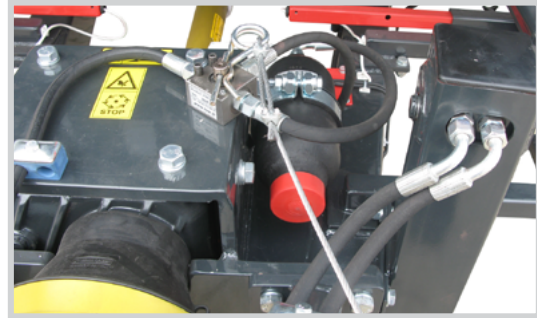

Hydraulic brake system

Alternative option

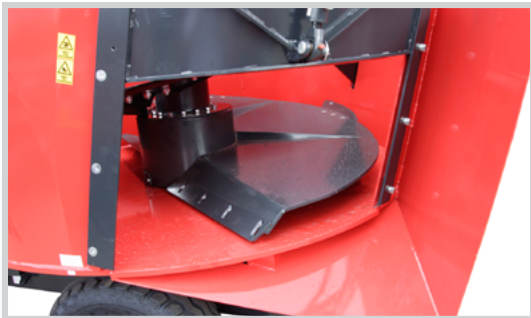

Discharge window



Two discharge windows



Two rear adjustable discharge windows

Alternative option

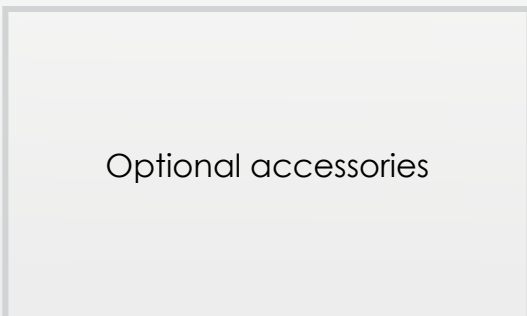

Optional accessories



Raised belt feeder

Alternative option

# Standard / optional accessories

Optional accessories



Side-mounted adjustable feeder

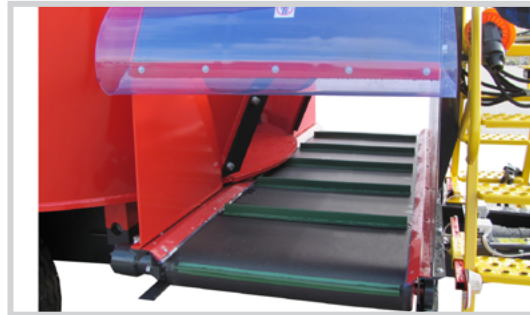

Cross belt feeder

Alternative option

Optional accessories



Road lights



Suspended ladder



Platform with single-sided access



Platform with double-sided access

Alternative option

## Standard / optional accessories



Mechanical parking jack

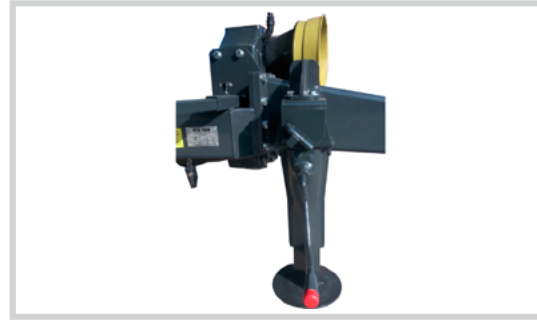

Mechanical parking jack



Hydraulic parking jack

Alternative option

**We can fulfil individual orders according with customers' needs and requirements.**



### SALES

ul. Kresowa 62, 16-100 Sokółka  
tel.: +48 85 711 07 88; fax: +48 85 711 07 89  
handel@metalfach.com.pl

### TECHNICAL SERVICE

ul. Kresowa 62, 16-100 Sokółka  
tel.: +48 85 711 07 80; fax: +48 85 711 07 93  
serwis@metalfach.com.pl

### SPARE PARTS WHOLESALE:

ul. Kresowa 62, 16-100 Sokółka  
**WHOLESALE:**  
tel.: +48 85 711 07 81; fax: +48 85 711 07 93  
hurtownia@metalfach.com.pl

### INDIVIDUAL SALE

tel.: +48 533 111 477 / +48 85 711 07 90  
sklep.kontakt@metalfach.com.pl

Metal-Fach Sp. z o.o. continuously improves its products and adapts them to suit the customers' needs; hence we reserve the right to modification without prior notice. Before making your purchase decision, contact an authorised dealer or Metal-Fach sales representatives. Metal-Fach Sp. z o.o. rejects all claims related to the data and photographic material contained in this price list. This offer is not a commercial offer as construed under the Polish Civil Code.

The illustrations may include non-standard accessories.

Original spare parts are available from authorised dealers and the Metal-Fach company store.

